

PRODUCT DESCRIPTION

MaxiSys MS909CV provides the full functionality and online repair information you need when diagnosing vehicles, identifying faults and researching repair issues. It features a powerful octa-core processor and 9.7-inch TFT-LCD capacitive touchscreen for swift diagnosis and optimum viewing. As an intelligent diagnostics and information system, MaxiSys MS909CV not only displays the relevant repair fixes and cases gathered from experienced industry experts, but provides step-by-step guidance to ensure the repair is done correctly and efficiently.

MaxiSys MS909CV has three main components:

- MaxiSys Display Tablet — the central processor and monitor for the system
- VCI — vehicle communication interface
- B200 — battery & electrical system tester

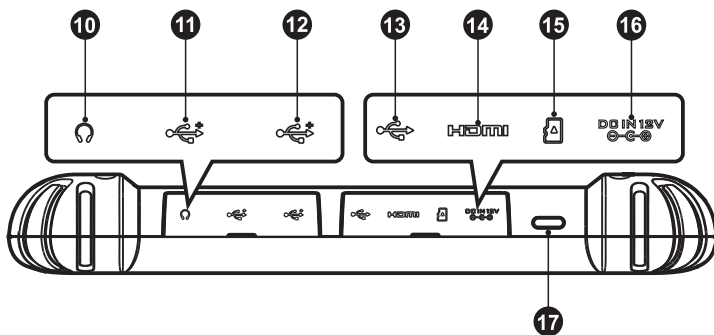
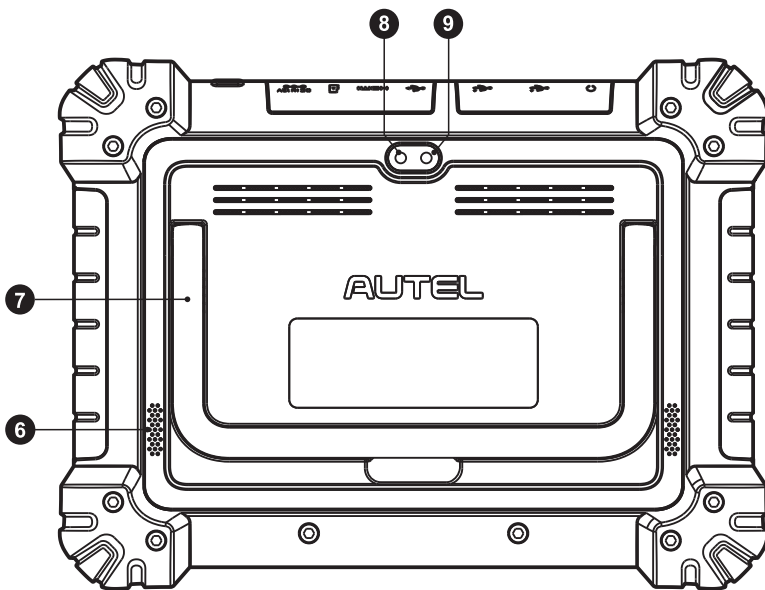
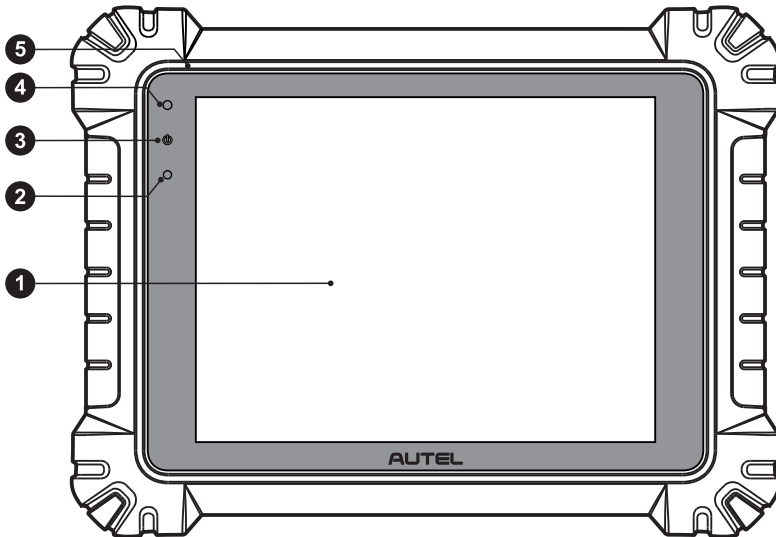

1. 9.7" TFT-LCD Capacitive Touchscreen
2. Ambient Light Sensor — detects ambient brightness
3. Power LED
4. Front Camera
5. Microphone
6. Speaker
7. Collapsible Stand — extends from the back to allow hands-free viewing of the tablet
8. Rear Camera
9. Camera Flash
10. Headphone Jack
11. USB Port
12. USB Port
13. Mini USB Port
14. HDMI (High-Definition Multimedia Interface) Port
15. Mini SD Card Slot
16. DC Power Supply Input Port
17. Lock/Power Button — long press to turn on/off the Display Tablet, or tap to lock the screen

MaxiFlash VCI

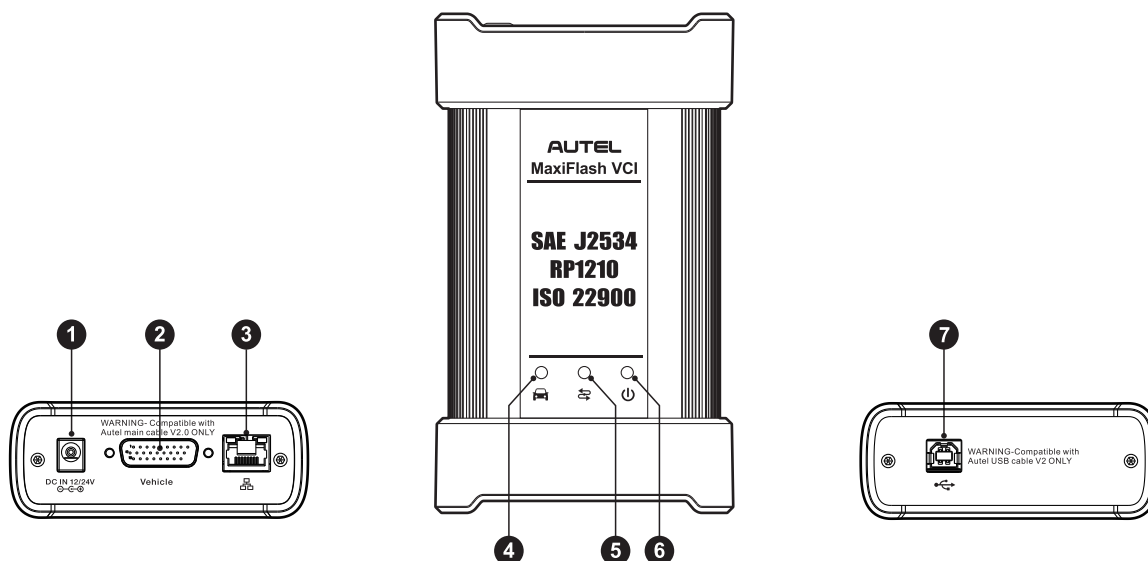

1. DC Power Supply Input Port
2. Vehicle Data Connector
3. Ethernet Port
4. Vehicle LED

5. Connection LED
6. Power LED
7. USB Port

LED Description

LED	Color	Description
Power LED	Yellow	The VCI is powered on and performing self-check.
	Green	The VCI is ready for use.
	Red	<ul style="list-style-type: none"> • Lights solid red when system failure occurs. • Flashes red when the VCI is upgrading.
Vehicle LED	Green	Flashes green when communicating with the vehicle.
Connection LED	Green	Lights solid green when the VCI is connected via USB cable.
	Cyan	Lights solid cyan when the VCI is connected via Wi-Fi.
	Blue	Lights solid blue when the VCI is connected via Bluetooth.

MaxiBAS B200

1. Power Button
2. Status LED
3. Power LED
4. USB Port
5. Battery Clamp Cable
6. Aviation Plug
7. Positive Clamp Cable Port
8. Negative Clamp Cable Port

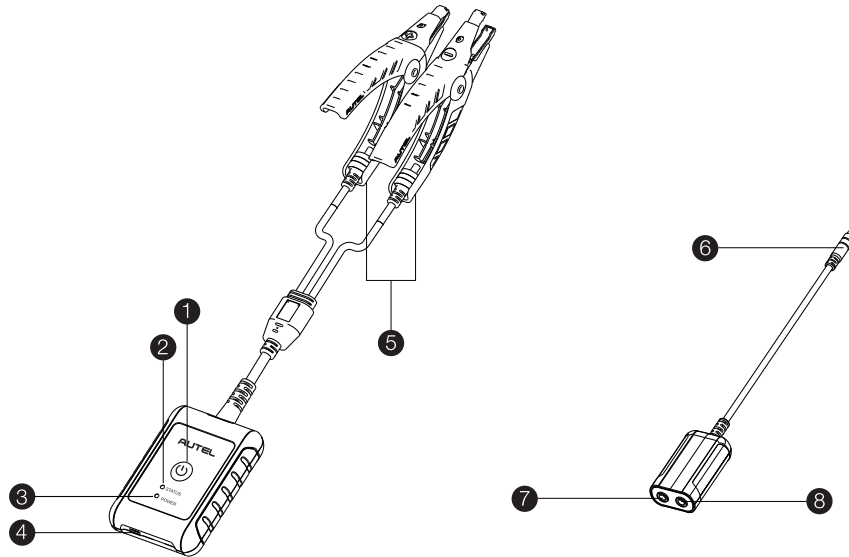

LED Description

LED	Color	Description
Status LED	Green	<ul style="list-style-type: none"> • Solid Green: The tester is connected via USB cable. • Flashing Green: The tester is communicating via USB cable.
	Blue	<ul style="list-style-type: none"> • Solid Blue: The tester is connected via Bluetooth. • Flashing Blue: The tester is communicating via Bluetooth.
	Red	<ul style="list-style-type: none"> • Flashing Red: Battery clamps are connected to the wrong battery terminals.
Power LED	Green	<ul style="list-style-type: none"> • Solid Green: The tester is powered on and the battery is sufficiently charged. • Flashing Green: The tester is charging; turns to solid green after its battery is fully charged.
	Red	<ul style="list-style-type: none"> • Flashing Red: The tester's battery level is low. Please charge.

GETTING STARTED



IMPORTANT: Before operating or maintaining this unit, please read these instructions carefully, and pay extra attention to the safety warnings and precautions. Failure to use this product properly may cause damage and/or personal injury and will void the product warranty.



WARNING: The MaxiFlash VCI is compatible with Autel main cable V2.0 and USB cable V2 only.

Establishing Vehicle Communication

1

Connect the main cable V2.0 to the Vehicle Data Connector on the VCI unit and tighten the thumb screws.

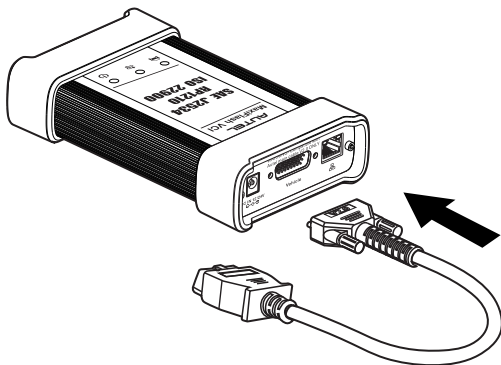

2

Connect the cable's 16-pin adapter to the vehicle's DLC, which is usually located under the vehicle's dashboard.

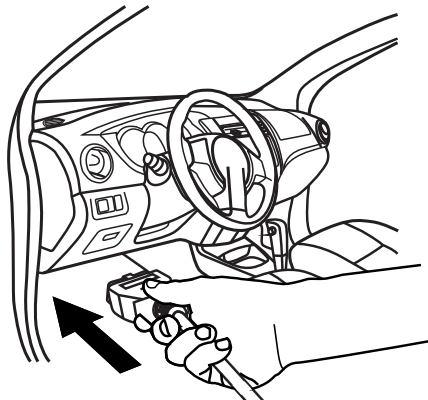

* Choose an adapter (Deutsch-6, Deutsch-9) according to diagnostic connector in the vehicle.

3

Power up the tablet. Ensure the tablet is sufficiently charged or is connected to the DC power supply.

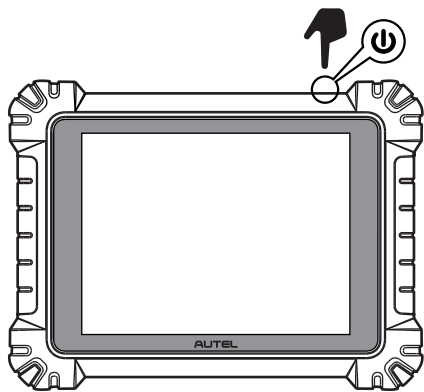

4

Select one of the three methods shown below (Bluetooth, Wi-Fi or USB cable V2) to connect the tablet with the VCI device and establish a communication link. Only use the supplied USB cable when programming.

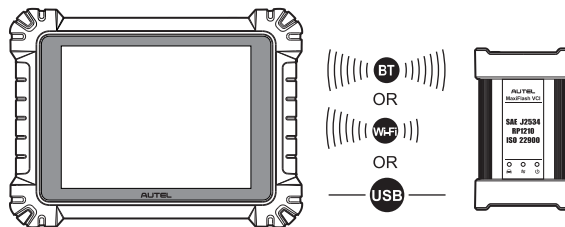

5

When the VCI device is properly connected to the vehicle and the tablet, the VCI status button on the bottom bar of the screen will display a green badge indicating the platform is ready to start vehicle diagnosis.

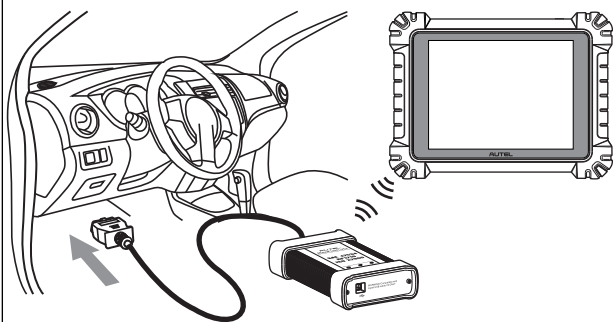

Inspecting the Battery

Before starting a test, observe the battery for:

- Cracking, buckling or leaking. If you see any of these defects, replace the battery.
- Corroded, loose or damaged cables and connections. Repair or replace as needed.
- Corrosion on the battery terminals, and dirt or acid on the case top. Clean the case and terminals using a wire brush and a mixture of water and baking soda. Wear protective glasses and gloves when working with batteries.



IMPORTANT: Please ensure that the MS909CV is powered ON when pairing the device and during registration.

Connecting to a Battery

1. Press and hold the **Power** Button to turn on the MS909CV. Ensure that the unit is sufficiently charged before using.
2. Enable Bluetooth on the MS909CV.
3. Open the Battery Test app and follow the on-screen instructions to pair the MS909CV with the B200 via Bluetooth.

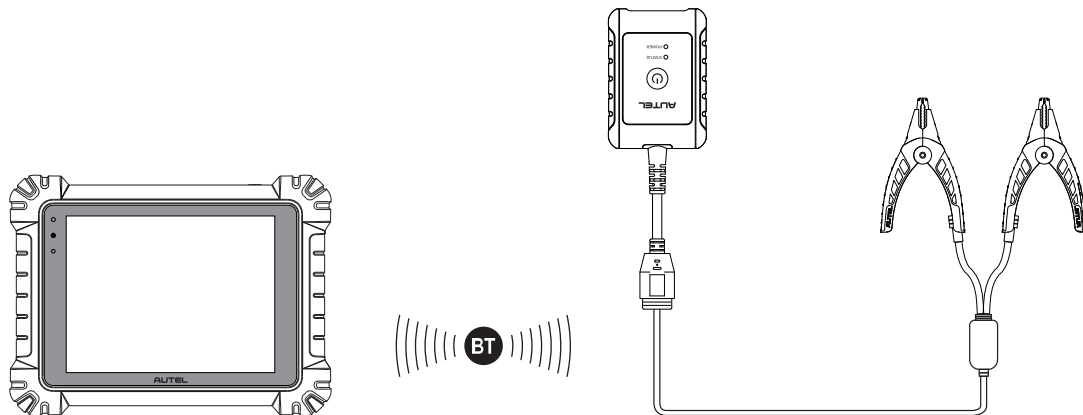

4. Connect the red clamp to the positive (+) terminal and the black clamp to the negative (-) terminal of the battery.

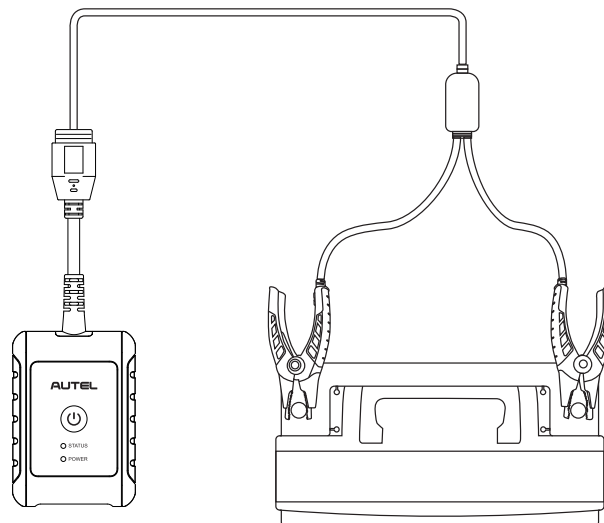

Connecting the Multimeter

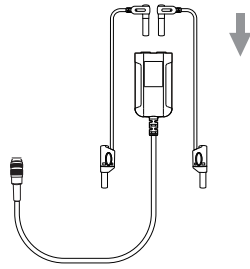

1. Plug the red test lead into the red input of the multimeter, and the black test lead into the black input.

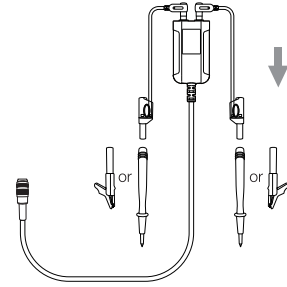

2. Connect the red alligator clip/red probe to the other end of the red test lead, and the black alligator clip/black probe to the black test lead.

3. Power on the MS909CV and tap the **Multimeter** button to enter the application.

4. Connect the multimeter to the multimeter cable port of the MaxiBAS B200 Series Tester and tighten the connector of the multimeter.

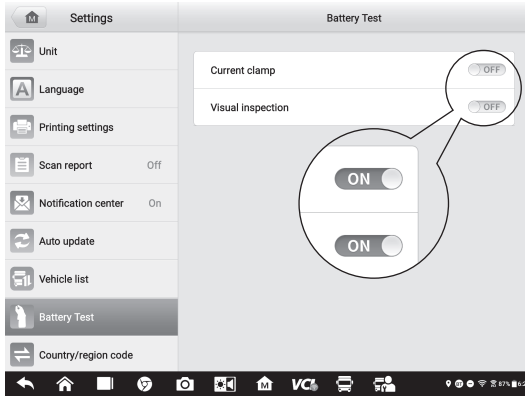
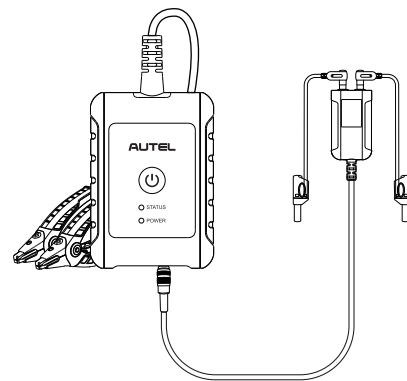

5. To use the current clamp with the multimeter when performing the in-vehicle test, tap the **Settings** icon. Locate the **Current clamp** on the menu list and swipe the toggle button to the **ON** position.

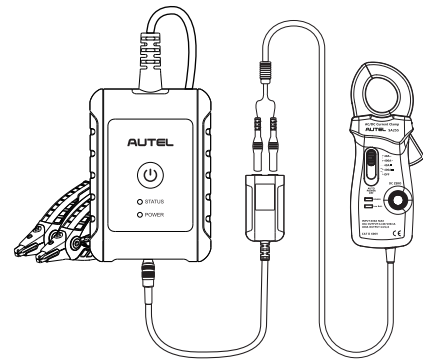

6. Plug the red output cable into the red input of the multimeter, and the black output cable into the black input. Connect the multimeter to the MaxiBAS B200 Series Tester and tighten the connector of the multimeter.

Thank you for purchasing this AUTEL MaxiSys MS909CV. Our tools are manufactured to a high standard and — when used according to these instructions and properly maintained — will provide years of trouble-free performance.